



LIEBHERR

ICBNd 5173 Fridge-Freezer

Fully Integrated

DIMENSIONS

H: 177.2 - 178.8 cm
W: 56 - 57 cm
D: 55.0 cm

VOLUME

Volume total 243 l
Refrigerator compartments 173 l
of which BioFresh 68.1 l
Freezer compartments 71 l
Of which 4-star compartment
70.9 l

MANAGEMENT AND FUNCTIONS

Control: 2.4" TFT colour display, Touch & Swipe display
Control unit: Touch & Swipe
Number of temperature zones: 3
Number of regulated refrigeration circuits: 2
Temperature display: Fridge, freezing compartment & BioFresh safe
Connectivity solution: retrofittable
Adjustable on appliance and via app: SuperCool, SuperFrost, Door alarm - cooling, Door alarm - freezing
Adjustable on app: BottleTimer, NightMode
Adjustable on appliance: Display lock

POWER AND CONSUMPTION

Energy efficiency class D
Energy consumption in 24h 0.569 kWh / 24h
Energy consumption per year 208 kWh/a
Climate class: SN-ST
Noise level: 34 dB
Sound emission class: B
Voltage: 220-240 V ~
Frequency: 50-60 Hz
Connection rating: 1.4 A 183 W

REFRIGERATOR COMPARTMENT

Adjustable temperature range: +3 °C to +9 °C
Moisture regulation: DuoCooling
Refrigerator compartment climate zones
· BioFresh with HydroBreeze
· Fish & Seafood safe
· Fruit & Vegetable safe
· Meat & Dairy safe
Freshness technology: BioFreshProfessional
Number of BioFresh safes: 2

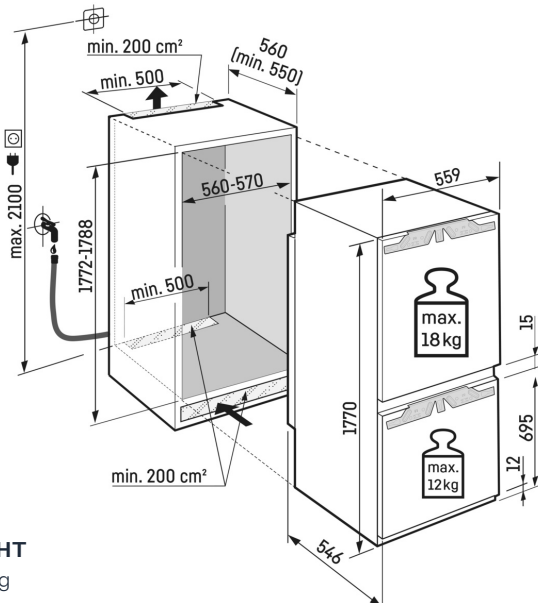

WEIGHT

80.8 kg



FINISH
White

Despite careful data management, our brands reserve the right to make changes, and discrepancies may occur.

MVP APPLIANCES

Head Office / Showroom Dubai
PO Box 37959, Dubai
+971 4 380 9490

Showroom Abu Dhabi
PO Box 28239, Abu Dhabi
+971 2 444 6160

Service Center
UAE 600 555 602



MVPAPPLIANCES.COM

ICBNd 5173 Fridge-Freezer Fully Integrated

Interior light of BioFresh safe: LED light extendible on telescopic rails
Variable uses as Fruit & Vegetable safe or Meat & Dairy safe: 1
Defrosting method: Automatic
Forced air cooling
FreshAir filter: in valve
Pull-out system drawer: Fully-extendible telescopic rails with self-closing mechanism and soft stop mechanism
SoftSystem
Number of storage shelves: 4
Of which separable: 1
of which height-adjustable: 3
Bottle storage: Integrated
Bottle rack: 1
Number of can racks: 1
VarioBox: Pull-out
VarioBoxes: 2
Butter dish
Egg tray: Variable
Number of FlexSystems: 1
Storage rack: Bottle and can rack
Height-adjustable inner door shelf: Gradual adjustment

INSTALLATION

Door assembly: Fixed door
Max. kitchen unit door weight: 18/12
Door hinges: Right reversible
Door hinge replacement: Possible for customer
Door opening angle: 115°
Door seal: Replaceable
Height-adjustable feet: 2
Levelling bars
Number of levelling bars: 2
Ventilation grates

FREEZER COMPARTMENT

Temperature range: -15 °C to -26 °C
Cooling technology: NoFrost
Freezer compartment position: Bottom
Defrosting method: Automatic
Storage time in case of fault according to GS: 9 h
Freezing capacity in 24 hours according to GS: 6 kg / 24h
No. of drawers in freezer compartment: 3
FrostSafe: Drawers closed on all sides with transparent front
Drawer pull-out system: Partially-extendible telescopic rails
Interior light: LED light
VarioSpace
IceMaker
Type of hose: Mains water hose with WaterStop
IceMaker safe lighting
Water inlet: Fixed water connection
Ice cube production: 1.2 kg / 24h
Ice cube storage: 5 kg
Number of cold storage accumulators: 2
Freezer tray: 1
Star-rating: 4

DESIGN AND MATERIALS

Dry rear panel
Material dry back wall: Stainless steel with SmartSteel
Inner door décor: SmartSteel
Design of inner door rack: Premium GlassLine
Material door shelves: Glass with stainless steel trim
Storage shelf material, refrigerator compartment: Glass
Material of adjustable shelves in the freezer compartment: Glass
Door material: Steel



Despite careful data management, our brands reserve the right to make changes, and discrepancies may occur.

MVP APPLIANCES

Head Office / Showroom Dubai
PO Box 37959, Dubai
+971 4 380 9490

Showroom Abu Dhabi
PO Box 28239, Abu Dhabi
+971 2 444 6160

Service Center
UAE 600 555 602

