



STRIPE Wall Mounted Cooker Hood

Duct-Out

FEATURES

Developed by Elica Design Center
Comfort silence technology
Delay switch off
Easy cleaning and maintenance
Maintenance alarm
Grease aluminium filter included
Chimney included

DIMENSIONS

W: 900 mm

LIGHTING

Type: LED 2x2,5 W
Intensity: 203 LUX
Temperature: 3000 K

PERFORMANCE

Controls: 3S+B Capacitive touch control
Min-max booster airflow: 300 - 900 m³/h
Total absorption: 265 W
Min-Max noise level: 50 - 65 db(A)
Duct size: 150 mm

OPTIONAL ACCESSORIES

Charcoal filter

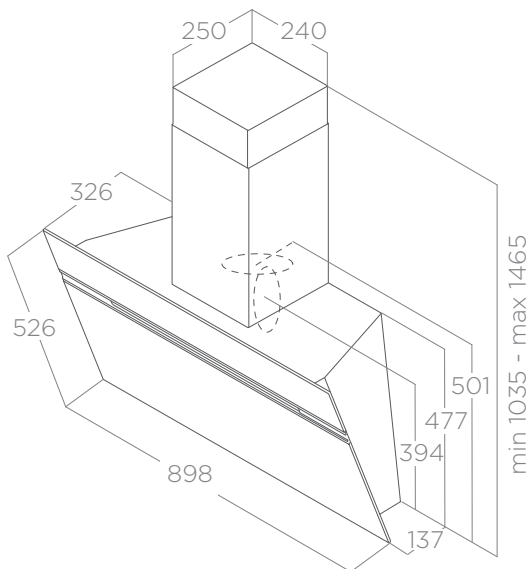

 **FINISH**
Black



MVP APPLIANCES

Head Office / Showroom Dubai
PO Box 37959, Dubai
+971 4 380 9490

Showroom Abu Dhabi
PO Box 28239, Abu Dhabi
+971 2 444 6160

Service Center
UAE 600 555 602



MVPAPPLIANCES.COM