



## BOXIN PLUS Built-In Cooker Hood

Duct-Out



### FEATURES

- Energy Class B
- Developed by Elica Design Center
- Multi-d capture
- Delay switch off
- Total integration
- Easy cleaning and maintenance
- Equipped with perimeter aspiration
- Grease aluminium filter included

### DIMENSIONS

Available in 3 sizes:  
W: 600 mm  
W: 900 mm  
W: 1200 mm

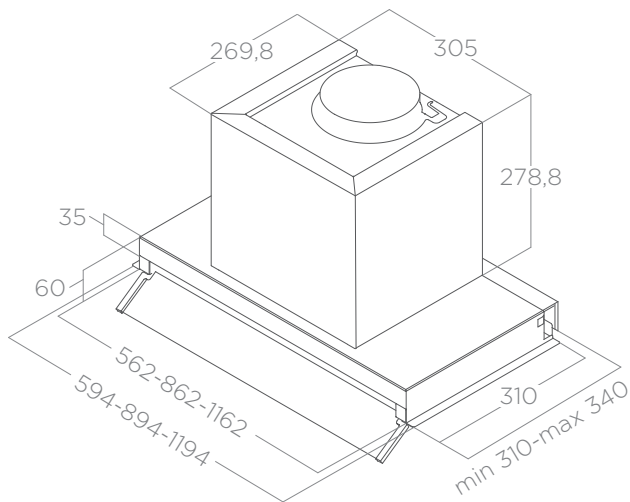

**FINISH**  
Stainless steel + White glass

### LIGHTING

Type: LED 2x2,5 W  
Intensity: 381 LUX  
Temperature: 3500 K

### PERFORMANCE

Controls: 3S Mechanical rotative  
Min-max airflow: 300 - 800 m<sup>3</sup>/h  
Total absorption: 255 W  
Min-Max noise level: 49 - 70 db(A)

### OPTIONAL ACCESSORIES

- Charcoal filter
- Regenerable charcoal filter
- Air diffuser grid kit 150 mm
- Chimney kit H12 IX
- Telescopic chimney kit



## MVP APPLIANCES

Head Office / Showroom Dubai  
PO Box 37959, Dubai  
+971 4 380 9490

Showroom Abu Dhabi  
PO Box 28239, Abu Dhabi  
+971 2 444 6160

Service Center  
UAE 600 555 602



MVPAPPLIANCES.COM