

ELBA

ELIO EIN 302 Domino Hob 30 cm

Induction Rectangular Zones

DIMENSIONS

W: 288 mm

D: 510 mm

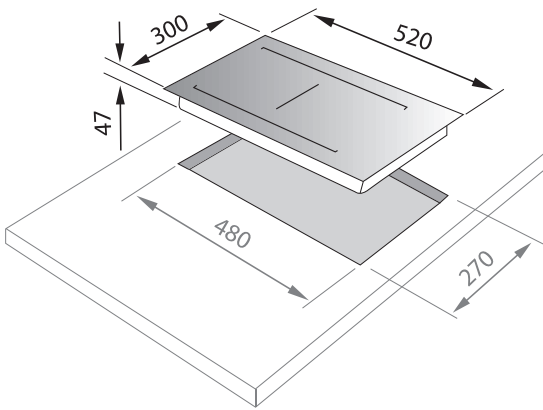

FEATURES

- 2 Induction rectangular zones
- 1 Full bridge zone
- Ceramic glass hob
- Stainless steel front trim
- Integrated backlit display
- Front touch control
- Chef cook function
- Minute minder and end of cooking programmer
- Easy Start system for automatic pan detection
- 12 Power levels such as Melting, Booster and Double Booster
- Residual heat indicator
- Cooling system (back air flow)
- Flush-mount installation

SPECIFICATIONS

- Total electric absorption: 3700 W
- Power Management from 1.4kW to maximum power
- Tension: 220-240 V ac; 380-415 V 3N ac; 380-415 V 2N ac

FINISH
Black glass

MVP APPLIANCES

Head Office / Showroom Dubai
PO Box 37959, Dubai
+971 4 380 9490

Showroom Abu Dhabi
PO Box 28239, Abu Dhabi
+971 2 444 6160

Service Center
UAE 600 555 602



MVPAPPLIANCES.COM